

# AD101<sup>EX</sup>

## ATEX-Rated Dust and Fume Filter Units

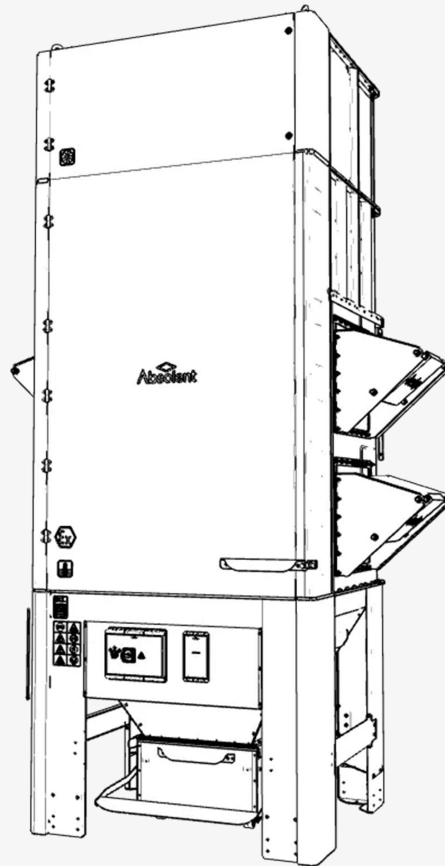

- Optimised for high performance, low energy use and extended filter lifespan
- Modular construction enables short lead times for bespoke solutions
- CleanChange™ system enables safe, quick and clean maintenance
- Low running costs through Vertical Airflow Technology and inverter-driven fan options
- Galvan pre-coated steel as standard for enhanced durability and long-term corrosion protection

### Modular filter unit for explosive dust and fume applications

Designed for ATEX-classified environments where combustible dust requires safe, compliant extraction. The modular filtration unit can be tailored to site conditions and performance requirements.

The Vertical Airflow Technology creates improved particle separation, directs dust to the hopper and reduces build-up on the filters. Stable operation and extended filter lifespan reduce maintenance and total cost of ownership.

CleanChange™ positions the filter change mechanism in the clean section, away from contamination. Maintenance is safe and quick, with linked filter elements for tool-free removal and no internal access required, reducing operator exposure.

## Function

AD<sup>EX</sup> models are modular filtration units for explosive dust and fume applications. Each unit can be specified to meet required airflow, pressure conditions, dust characteristics and zoning requirements for installation in ATEX-classified environments.

Vertical Airflow Technology combines a downflow air pattern with vertical filter elements. The airflow directs separated dust into the dust disposal solution and ensures that, after pulse jet cleaning, released dust is guided downwards. The incoming airstream scours the vertical filter elements during operation, creating a two-stage cleaning effect that helps maintain filtration efficiency.

Vertical filter elements prevent dust from accumulating on top surfaces, as can occur with horizontal configurations. Dust removed during cleaning is directed straight into the dust disposal solution rather than onto elements below.

Filter condition is monitored by a differential pressure sensor. Pulse jet cleaning is activated on demand based on pressure drop, maintaining stable performance while reducing compressed air consumption and energy use.

## Applications



Food Processing



Chemicals

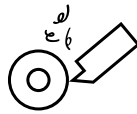

Dry machining



Textiles



Grinding



Plastics



And more

## Explosion protection devices and safety zones

The filtration unit is equipped with explosion protection devices according to its ATEX classification and application risk assessment. Depending on the unit size and hazard level, one to three devices may be installed. The type and quantity of devices determine the required safety zones, which must always be kept free from personnel and combustible materials.

On AD051EX units, devices are located on the rear side and may consist of one to two explosion panels, one to two diverters, or one flameless vent. On AD101EX and AD151EX units, devices may be installed on the left-hand side, right-hand side, rear side, or a combination of two sides, and may consist of one to three explosion panels or diverters, or one to two flameless vents.

### Explosion panel

Explosion panels are the standard solution for explosion protection. In the event of an explosion, the panel opens rapidly and relieves pressure, flame, and hot gases directly into the surrounding area.

This solution requires a large safety zone in the discharge direction, both at floor level and vertically. The released flame and pressure can extend several meters, and no personnel or equipment may be present within this zone. Explosion panels are typically used where sufficient free space is available and where discharge to a safe area can be ensured.

**Safety zone:** Safety zone according to EN 14491 based on unit volume and device-specific documentation.

### Explosion diverter

The explosion diverter is used together with an explosion panel and redirects the explosion discharge away from the immediate surroundings. It reduces the safety zone at floor level by guiding the explosion effects upward and forward.

This results in a smaller restricted area on the floor compared to a standard explosion panel. However, a significant safety zone remains at elevated levels, where flame and hot gases are directed. This solution is suitable for installations where floor space is limited but sufficient vertical clearance is available.

**Safety zone:** Floor-level hazard zone: 2 m × 5 m. Elevated hazard zone: 10 m × 5 m, from 2 m to 12 m above floor level.

### Flameless vent

The flameless vent integrates an explosion panel with a flame filter that cools and retains flame and hot particles. During an explosion, pressure is released while flame propagation is prevented.

This solution provides the smallest safety zone and eliminates external flame, making it suitable for indoor installations and confined spaces. The safety zone is limited to a short distance in front of the device, significantly reducing installation constraints compared to venting solutions. The flameless vent absorbs explosion energy and prevents flame transmission to the surrounding area, thereby protecting personnel and equipment.

**Safety zone:** Fan-shaped area extending horizontally along the floor in the discharge direction for 2 m, with a height up to 2 m. Minimum clearance to obstruction: 0.5 m.

**Limitation:** Flameless vents are not certified for conductive dust (ATEX dust class IIIC). They may only be used for non-conductive dust (IIIB).

## Dimensions

The AD range is modular and configured according to the application. Unit size and layout may vary depending on the selected configuration, dust class, explosion relief solution, and any additional modules, such as HEPA filters or integrated fans. The drawings below show typical dimensions only. Actual dimensions, as well as the placement of explosion relief, may vary.

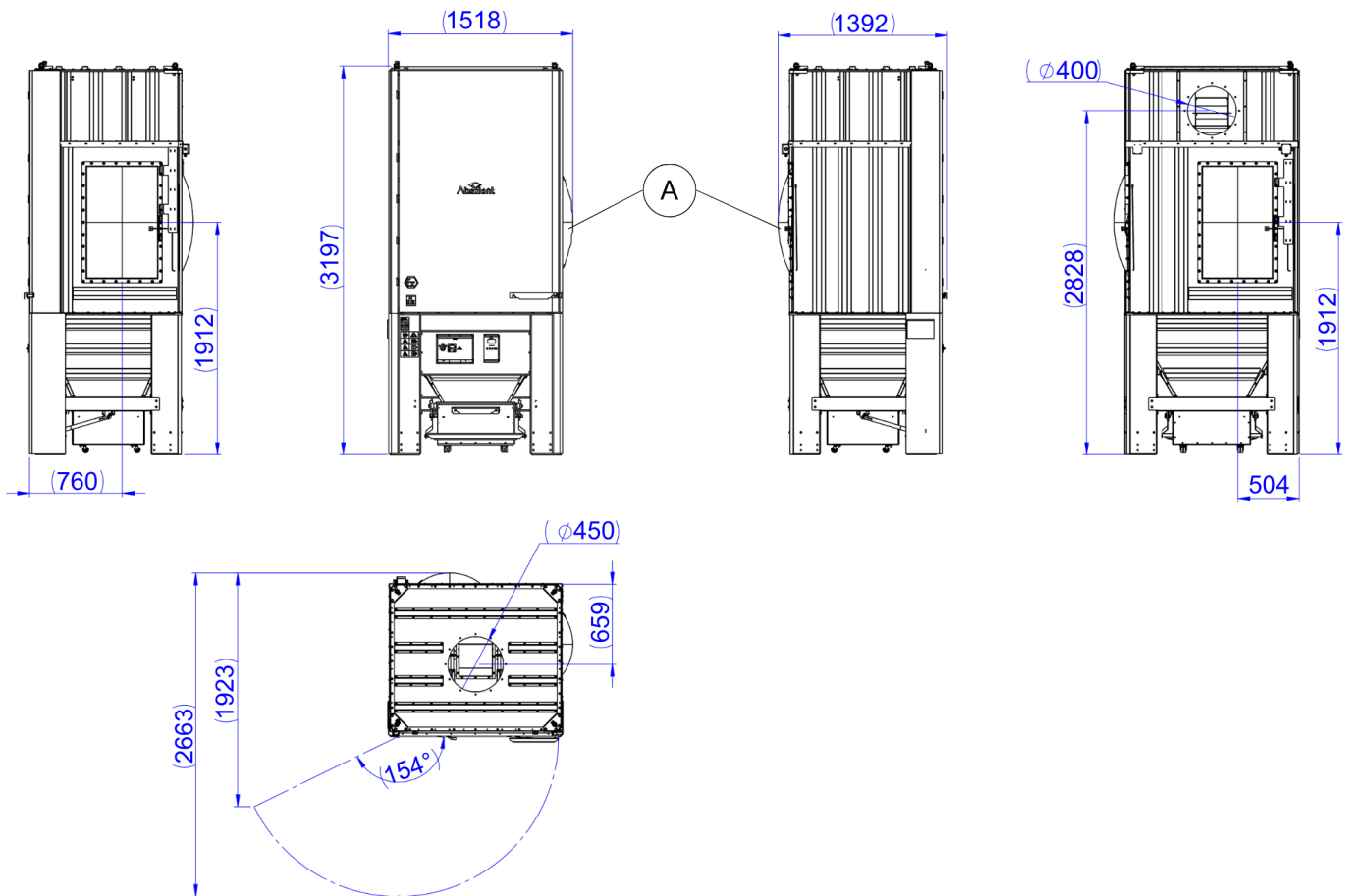

AD101EX with external fan and two explosion panels (A).

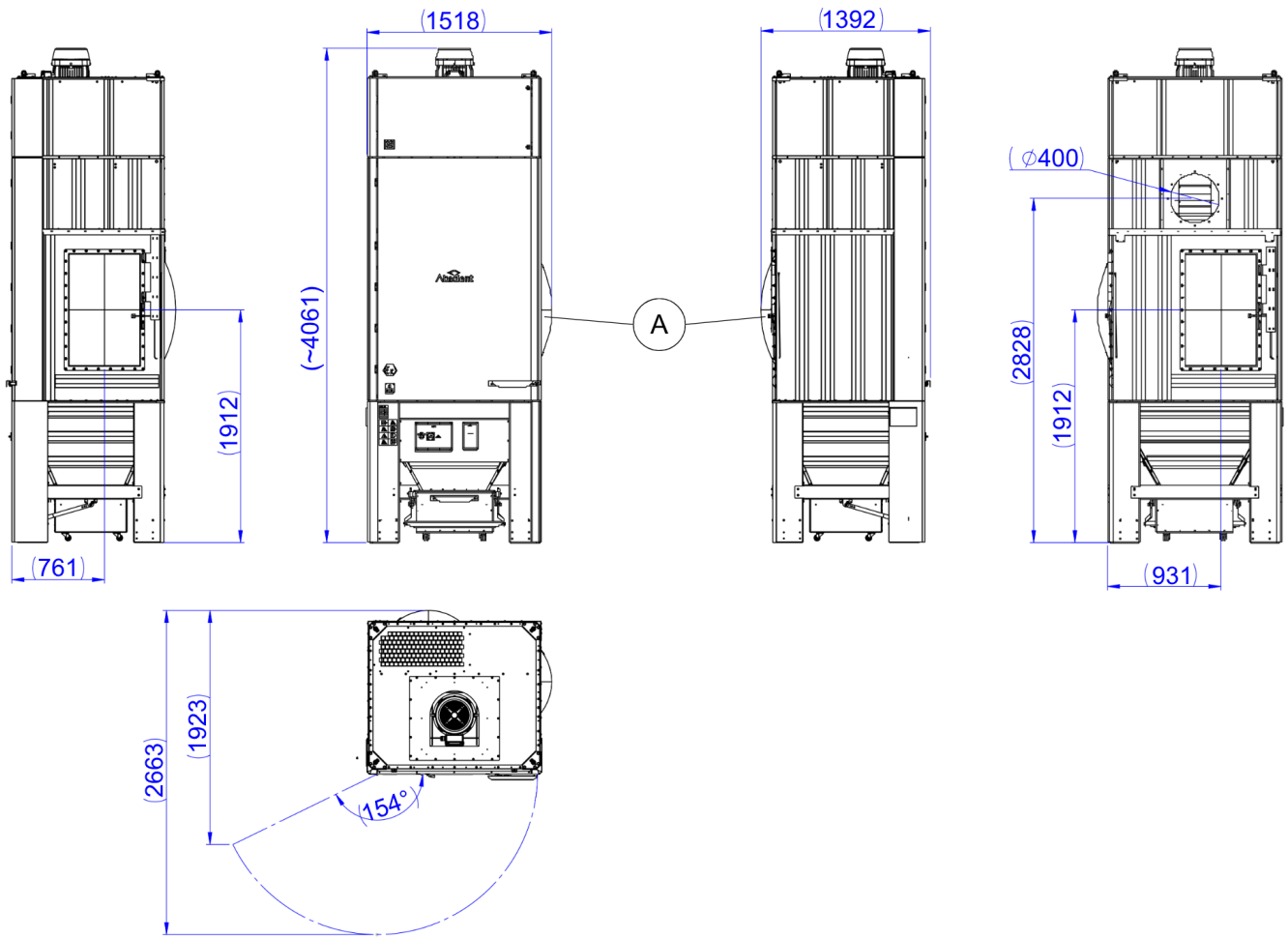

AD101EX with integrated fan and two explosion panels (A).

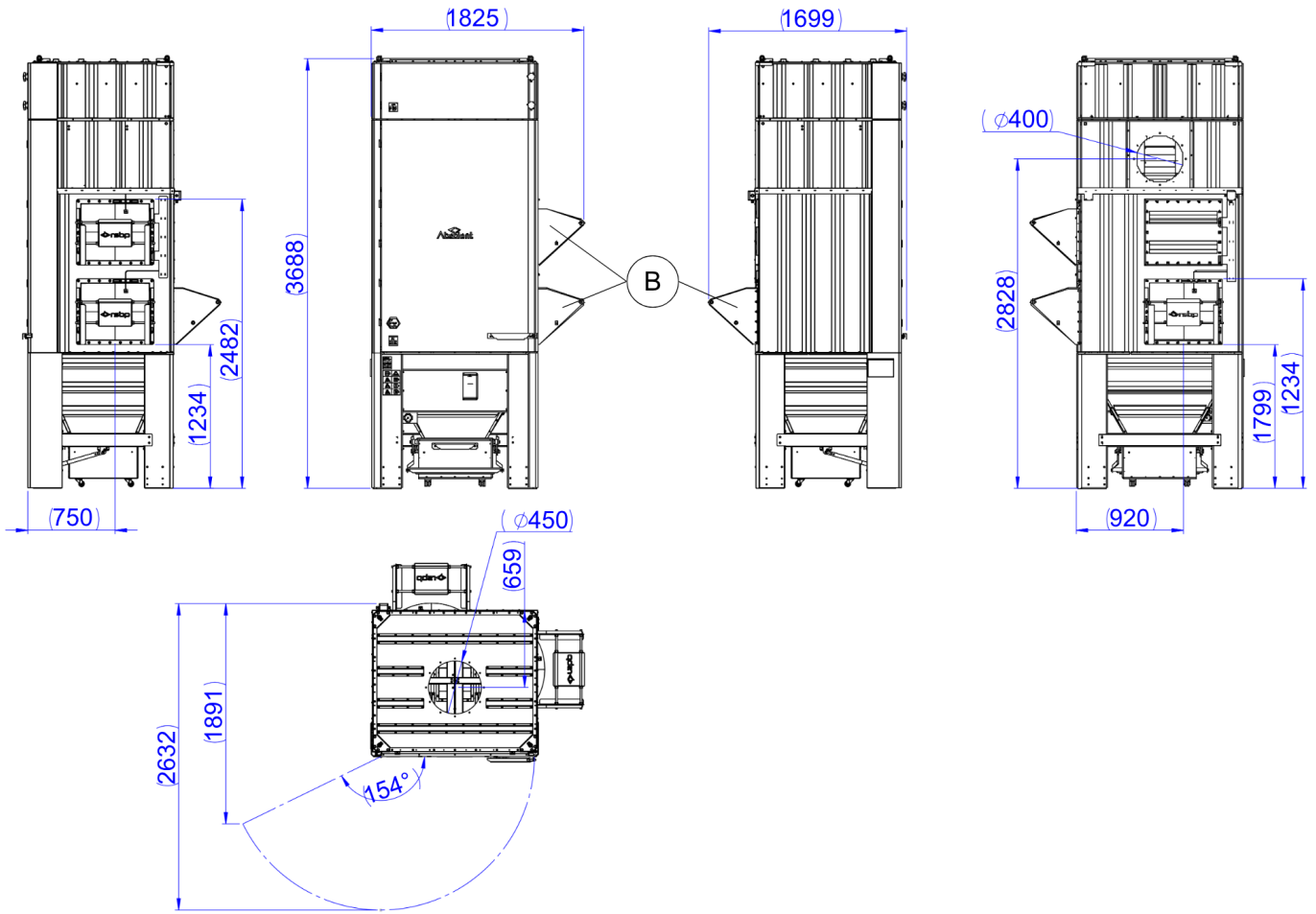

AD101EX with external fan, three explosion diverters (B) and HEPA module.

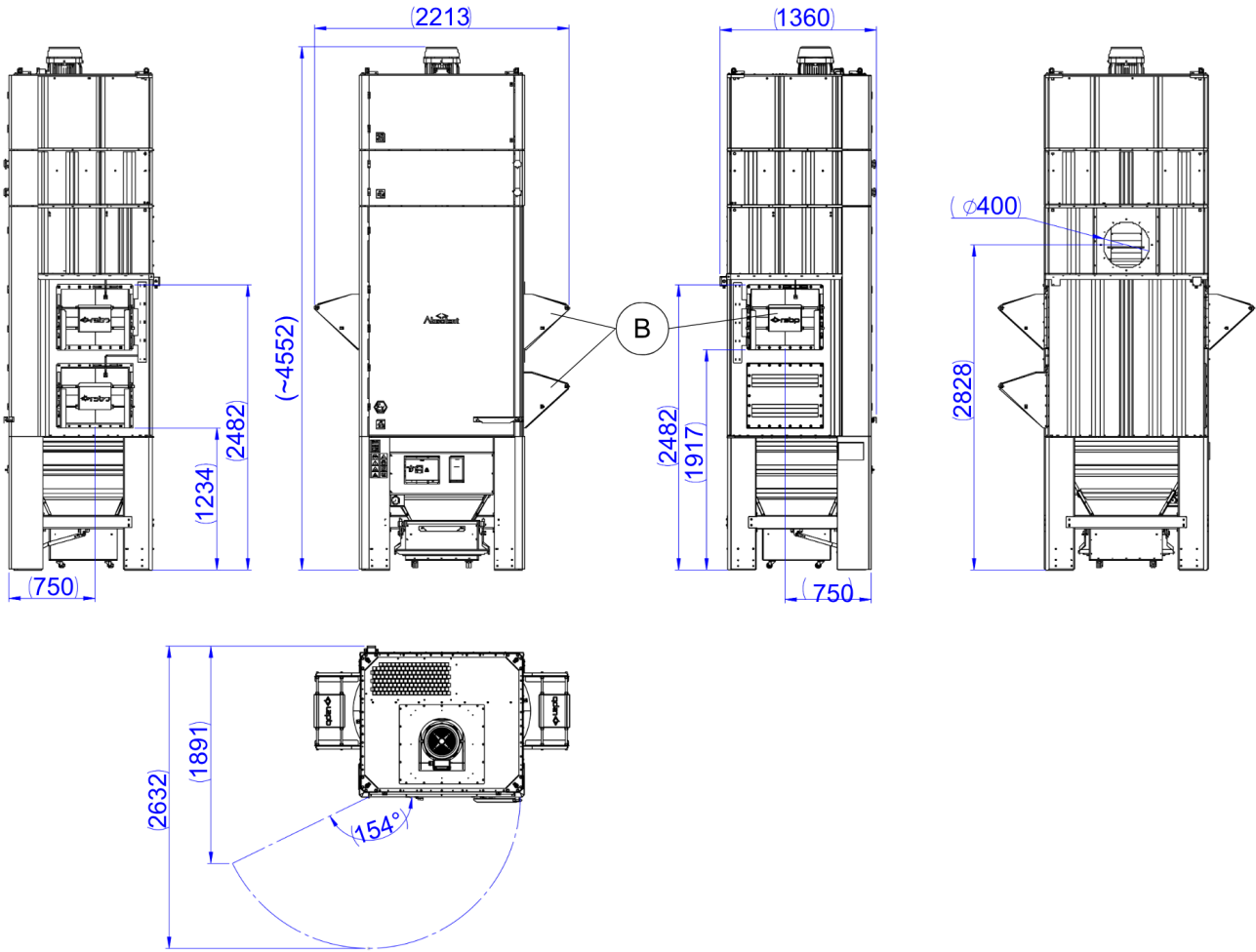

AD101EX with integrated fan, three explosion diverters (B) and HEPA module.

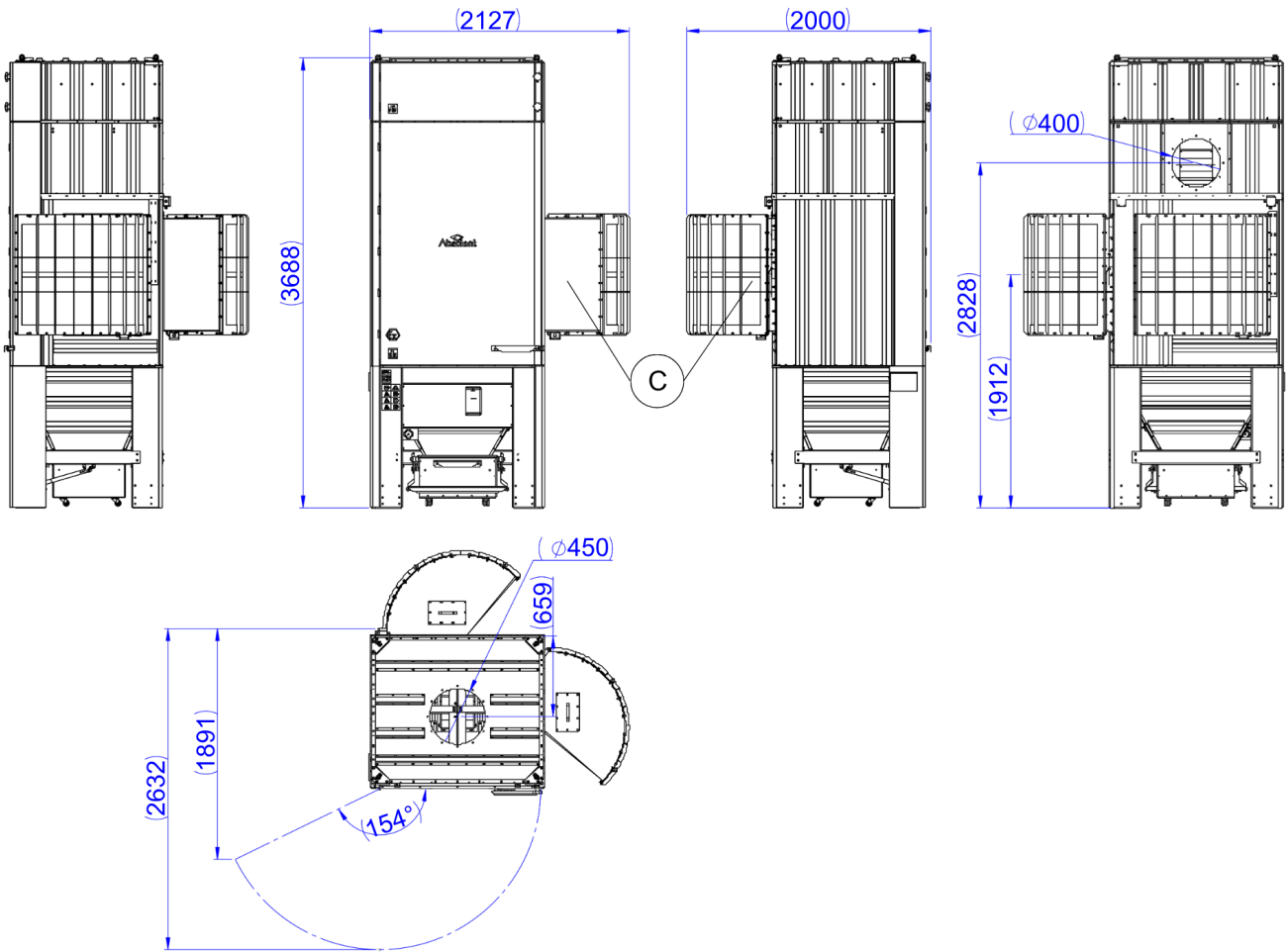

AD101EX with external fan, HEPA module and two flameless vents (C).

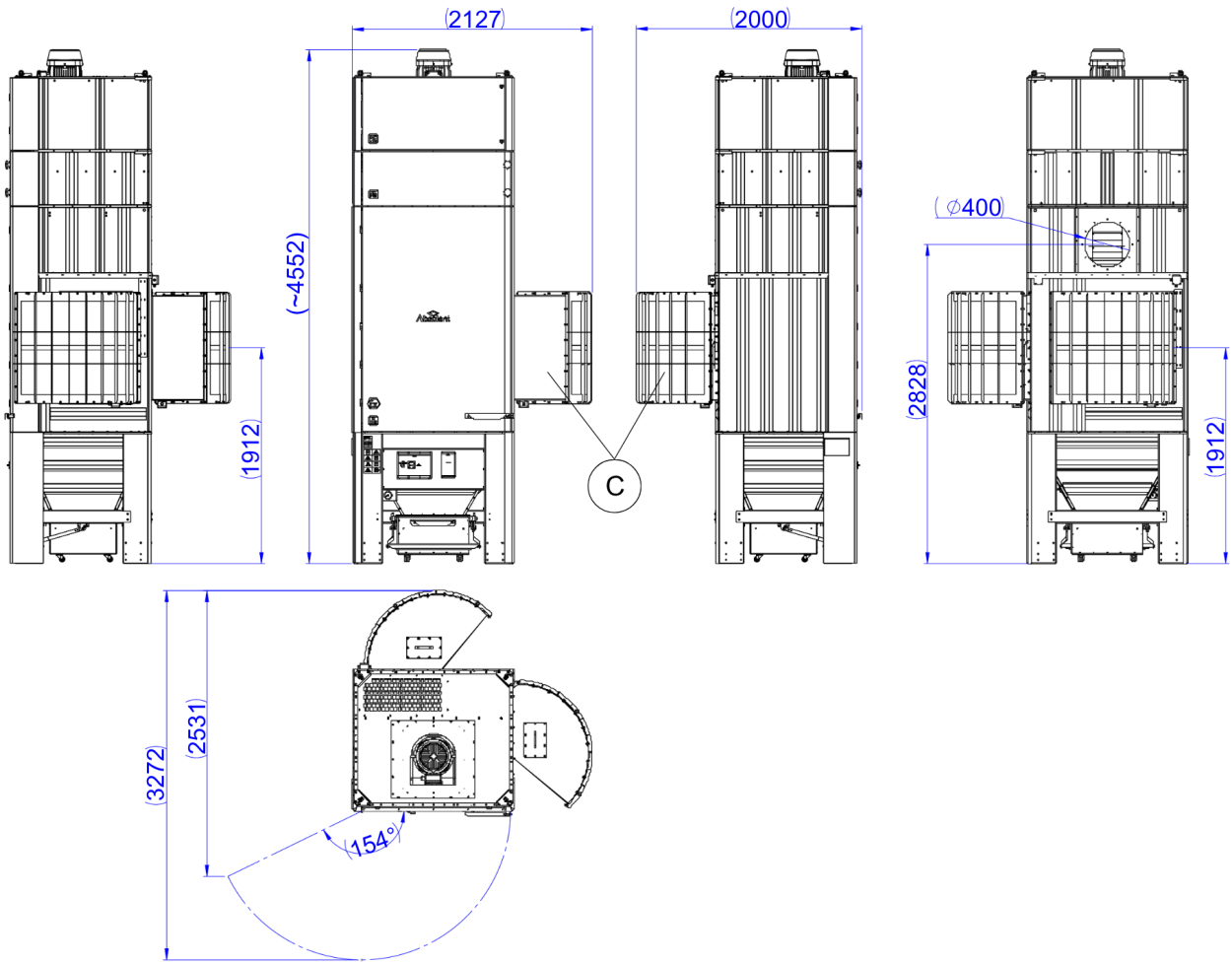

AD101EX with integrated fan, HEPA module and two flameless vents (C).

## Technical specifications

	AD101 <sup>EX</sup> with integrated fan	AD101 <sup>EX</sup> with external fan
<b>General</b>		
Application	Explosive Dust. Suitable for Internal & External Use	Explosive Dust. Suitable for Internal & External Use
Airflow range	2 400-7 200 m <sup>3</sup> /h	2 400-7 200 m <sup>3</sup> /h
Maximum external pressure	3 000 Pa	N/A
Pressure drop of the unit	2 000 Pa	2 000 Pa
Fan motor power	7,5 kW (10.06 hp), 11 kW (14.75 hp), 15 kW (20.12 hp)	N/A
Energy class	IE3	N/A
External Finish	Galfan pre-coated steel, high corrosion resistance	Galfan pre-coated steel, high corrosion resistance
Location	Indoor and outdoor use. <sup>1</sup>	Indoor and outdoor use.
Delivery	Delivered in sections	Delivered in sections
<b>ATEX</b>		
Internal <sup>2</sup>	II 2/3D Ex h IIIC T125°C Db/Dc	II 2/3D Ex h IIIC T125°C Db/Dc
External <sup>3</sup>	3D	3D
Zone suitability - Internal	Zone 21 / 22	Zone 21 / 22
Zone suitability - External	Optional Zone 22	Optional Zone 22
Protection type	Ex h	Ex h
Dust group	IIIC (conductive dust)	IIIC (conductive dust)
Max surface temperature	T125°C	T125°C
Max KST Value (Horizontal)	1 x 586x920 panel - 299 KST 2 x 586x920 panels - 559 KST	1 x 586x920 panel - 299 KST 2 x 586x920 panels - 559 KST
Max KST Value (Vertical)	1 x 490x590 panel - 100 KST 2 x 490x590 panels - 250 KST 3 x 490x590 panels - 323 KST	1 x 490x590 panel - 100 KST 2 x 490x590 panels - 250 KST 3 x 490x590 panels - 323 KST
Max KST Value (Flameless)	1 x 450x800 Flex PRO R2 vent - 150 KST 1 x 586x920 Flex PRO R3 vent - 199 KST 2 x 586x920 Flex II R3 vent - 299 KST	1 x 450x800 Flex PRO R2 vent - 150 KST 1 x 586x920 Flex PRO R3 vent - 199 KST 2 x 586x920 Flex II R3 vent - 299 KST
Explosion protection <sup>4</sup>	Rupture panel / panel with diverter / flameless vent	Rupture panel / panel with diverter / flameless vent
<b>Connections</b>		
Inlet type	DIN 24154/T2	DIN 24154/T2
Inlet diameter	400 mm (15.75 in)	400 mm (15.75 in)
Inlet placement	Rear	Rear
Outlet type	Free flow via integrated fan or duct connection (optional accessory).	Open DIN 24154/T2 connection.
Outlet diameter	450 mm (17.72 in)	450 mm (17.72 in)
Outlet placement	Top	Top
Compressed air supply	12 mm connection - 6 Bar Clean & Dry Supply	12 mm connection - 6 Bar Clean & Dry Supply
Electrical information	400 V, 3 phase, 50 Hz	N/A
<b>Dust collection</b>		
Bin	115l (30.4 gal (US))	115l (30.4 gal (US))
<b>Filter</b>		
Diameter Primary filter elements	324 mm	324 mm
Number of Primary filter elements	4 pcs	4 pcs
Filter efficiency	All filter elements are in accordance with EN 60335-2-69:AA Dust Class M Rating. Dust Class M relates to an efficiency of > 99.9% under conditions given in EN 60335-2-69:AA.	All filter elements are in accordance with EN 60335-2-69:AA Dust Class M Rating. Dust Class M relates to an efficiency of > 99.9% under conditions given in EN 60335-2-69:AA.
Filter media	Anti-Static Eco Polyester & Polyester Nano Fibre	Anti-Static Eco Polyester & Polyester Nano Fibre
Total Filter area	80 m <sup>2</sup>	80 m <sup>2</sup>
Filter cartridge length	1200 mm (47.24 in)	1200 mm (47.24 in)
Secondary filter	HEPA H13 filter	HEPA H13 filter
Number of HEPA filter cassettes	4	4
Pre-treatment (Pre-coating Powder)	Yes, as option	Yes, as option
<b>Physical properties</b>		
Width <sup>5</sup>	1518 - 2213 mm (59.76 - 87.13 in)	1518 - 2213 mm (59.76 - 87.13 in)
Height	4061 mm (159.88 in)	3197 mm (125.87 in)
Height with HEPA filtration stage	4552 mm (179.21 in)	3688 mm (154.20 in)
Depth	1392 - 2000 mm (54.80 - 78.74 in)	1392 - 2000 mm (54.80 - 78.74 in)
Weight with empty filter cartridges <sup>6</sup>	1243 - 1567 kg (2740 - 3454 lb)	912 - 1178 kg (2011 - 2597 lb)
Weight with HEPA filtration stage	1433 - 1757 kg (3159 - 3873 lb)	1102 - 1368 kg (2429 - 3015 lb)
<b>Sound level</b>		
Sound level Continuous (fan) <sup>7</sup>	75 db(A)	75 db(A)

<sup>1</sup>Outdoor placement requires optional weather protection accessories.

<sup>2</sup>Units equipped with flameless vents are limited to II 2/3D Ex h IIIB T125°C Db/Dc and are not approved for conductive dust (IIIC). IIIC-rated units are only available with explosion panels and diverters.

<sup>3</sup>Zone 22 with Fan Starter / VFD provided loose to allow positioning outside of the ATEX zone

<sup>4</sup>Unit is equipped with one explosion protection solution based on ATEX classification and application. Configuration may include one or more panels, panel(s) with diverter(s), or flameless vent(s).

<sup>5</sup>The measurement depends on the selected explosion protection device.

<sup>6</sup>The unit weight depends on the selected explosion protection device and ATEX class and is therefore given as a range.

<sup>7</sup>The sound level is measured 1 m from the filter unit under free field conditions. Contact Absolent or dealer/distributor for sound calculation on specific location.

## Dust disposal options

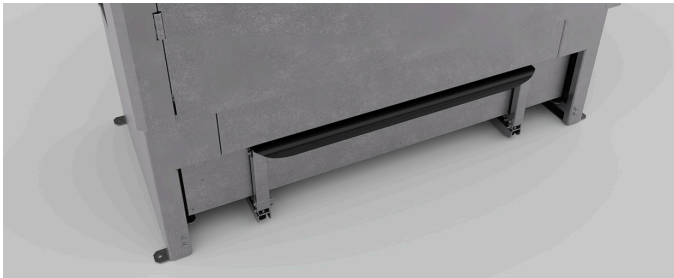

**Dust collection drawer**

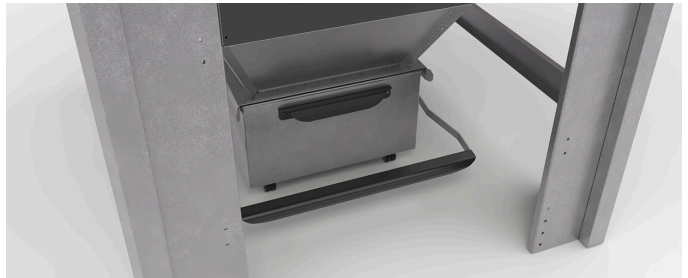

**Dust collection bin**

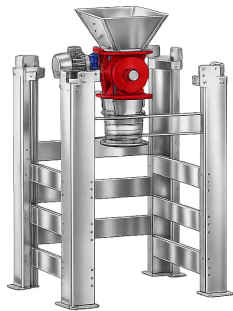

**Extension legs with rotary valve and drum connection**